



7,000-Pound Capacity Four-Post Series  
CERTIFIED PRODUCT – NO  
ANSI TEST WEIGHT CRITERIA – UNKNOWN



vs.



9,000-Pound Capacity Four-Post Series  
ANSI/ALI ALCTV-2006 CERTIFIED PRODUCT  
ANSI TESTED WEIGHT CRITERIA - 27,000 POUNDS



## Separating Fact from Fiction

Remember – just because you pay more for something, doesn't make it better. In the highly competitive auto lift business, especially the DIY sector, many judgments are being passed on with no merit based solely on prices consumers are being quoted. Always study thoroughly, then look, compare and decide.



### Statement from their website and other Marketing Materials

"As the largest manufacturer of four-post freestanding auto lifts for the residential and commercial market, BYB is proud to offer a full-line of lifts for cars, trucks and recreational vehicles of all kinds."

### BendPak Response

BendPak has 72 unique lift models in their lineup ranging from lightweight to super-duty. BYB could not come close to a fraction of lifts BendPak sells globally - and not just "hobby" lifts. Investigate thoroughly on the web using various search engines to see how many pages BYB appears on compared to a true world-leader like BendPak.



### Statement from their website and other Marketing Materials

"Our automotive lifts for home use offer accessory kits like solid inserts and drip pans which make our lifts much more versatile than you may expect. They are perfect for storing ATV's, snowmobiles and other seasonal vehicles while providing usable space under the elevated platform."

### BendPak Response

BendPak can supply these valuable options as well.



### Statement from their website and other Marketing Materials

Need professional installation of your new automotive lift? Contact us anytime from 8 a.m. to 5 p.m. EST and you will be connected to a live person at a real manufacturer."

### BendPak Response

BendPak has over 650 installation and service centers located in the United States - fully equipped installation and service centers with truck fleets that make a living installing and servicing large car dealerships, national accounts, auto repair centers and occasional auto enthusiasts and DIY'ers.





### Statement from their website and other Marketing Materials

"Sometimes called car lifts, truck lifts, car hoists, drive on car lifts, automotive lifts or vertical platform lifts, our freestanding four post auto lifts are perfect for your home garage and come with the best construction and design on the market making them the safest product available at the best value. We are proud to offer a super lift that will bring you years of enjoyment."

### BendPak Response

BendPak has a staff of seven full-time engineers who do nothing but design, test, and evaluate lift systems. BendPak lifts have changed and evolved over the past 40-years not because they like making changes but because they are constantly improving the structural integrity and design of their lifts to meet constantly changing world standards. On the surface, many lifts look "engineered", but what lies under the surface? All BendPak lift designs are computer modeled for design function and structural integrity then undergo simulation of applied forces, axial force, bending moment, etc. using Solid Works Cosmos and other FEA programs. After the design is sound, they proceed with actual destructive (physical) testing.

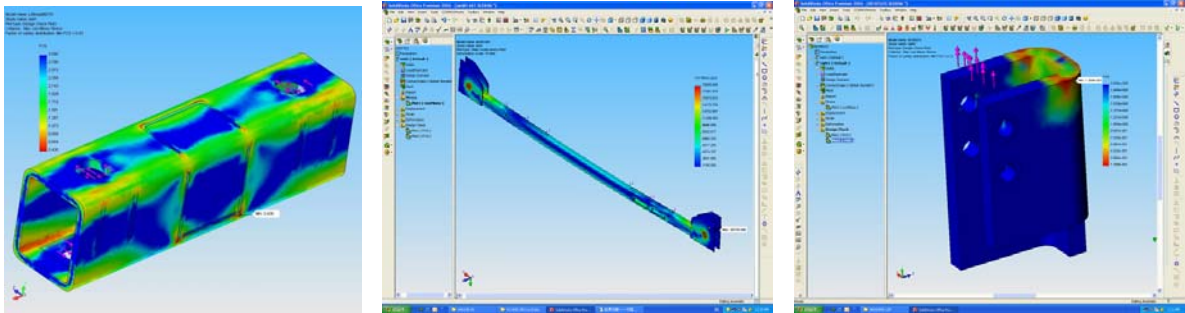

There is only one real national lift standard for quality and safety - OSHA endorsed ANSI/ALI ALCTV-2006. If you don't see any reference to this standard, then ask yourself if saving a few extra bucks on a non-certified lift is really worth jeopardizing the safety of you and your loved ones. BendPak gives you value, but more important, a piece of mind. Combine that with their worldwide distribution, sales and service coverage, means you can count on BendPak to deliver their promise of total customer satisfaction.



### Statement from their website and other Marketing Materials

"Don't rely on automobile scissor lifts or cheap drive on auto lifts to handle your precious cargo or your safety. Economy platform lifts, which are most often imported, may appear to have attractive prices but they severely cut corners in the areas of quality, design, performance and safety."

### BendPak Response

Why are BYB lifts not approved to meet the requirements of ANSI/ALI ALCTV-2006? - Quite simply, because their lifts could not pass the standard. Particularly their lack of a slack-cable lock system, a substantiated engineering report from an accredited PE (professional engineer) verifying that all components could withstand a load of 300% capacity with no permanent yield or deformation of any kind, their absence of an ample cable guard to prevent unintentional displacement, and more.

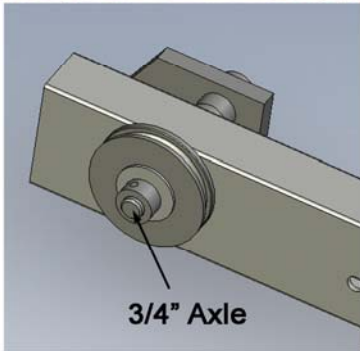
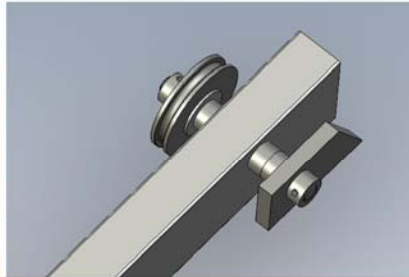

Narrow sheaves supported at one side only.

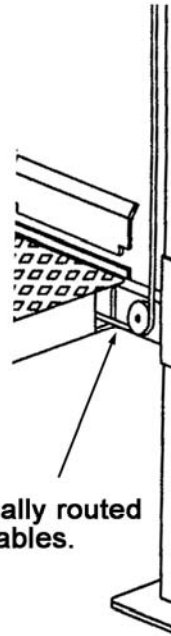

Externally routed cables.

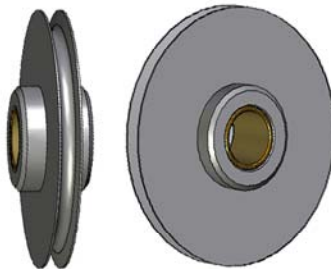
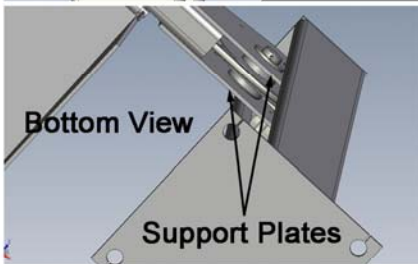
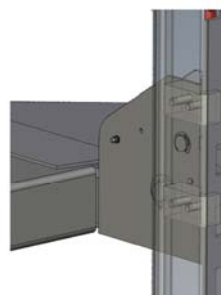
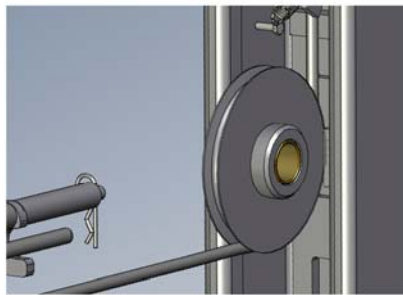
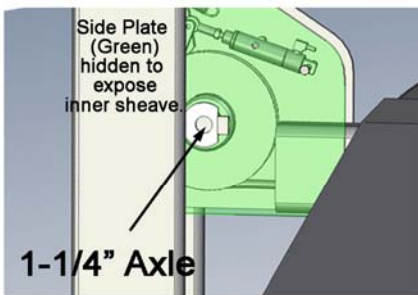

Dual-hub sheaves have 4x the bearing surface.

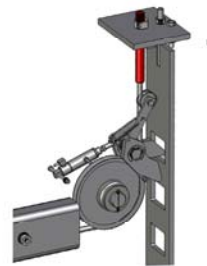

BENDPAK PHOTO-HD-9 SEREIS



### Common Misleading Claims:

- Claims that state "Meets or Exceeds Standard ANSI/ALI B-153.1" are meaningless. This standard no longer exists.
- Claims that state "Meets all ANSI Standards" are meaningless. No other standards apply to lift construction except ANSI/ALI ALCTV. In order to meet ANSI/ALI ALCTV, Certification is required. Look for the Mark.
- Claims that state "Meets all OSHA Requirements" are meaningless. OSHA has no requirements governing automotive lifts, but they do write citations applying to automotive lifts. They do this under the General Duty Clause and recommend to those cited that it would be prudent for the cited party to follow the directives in the various standards developed by ALI.

Any claim that implies "This lift is ALA Certified" is worthless. ALA (Automotive Lift Association) is reported to be an organization of suspect lift suppliers with no endorsement by ANSI or OSHA. ALA appears to be purely fictitious and created merely to confuse purchasers, users and inspectors.

Any claim that implies "This lift is MAMTC Certified" is worthless. MAMTC (Mid-America Manufacturing Technology Center) is a unit of Wichita State University which, in one instance, attempted to certify a lift model. Test Reports on MAMTC letterhead stated that a particular lift complied with ANSI B153.1 – 1990. Of course this is meaningless because MAMTC is not a NRTL (Nationally Recognized Test Facility), and the standard cited is obsolete.

The proliferation of Asian products in this country is making it difficult to remain competitive, but remaining competitive should not be a trade-off to remaining safe. Even some Asian brands look OK but judging a lift solely on cosmetic appearance can be perilous. Mechanical properties of steels vary considerably and although a lift component may "look like steel", what kind of steel is it? GB/T 699 15Mn steel - 59,000 lbs. tensile / GB/T 700 Q235A steel - 54,000 lbs. tensile / IS 10748 Grade 1 steel - 24,650 lbs. tensile / A512 Grade 1018 steel - 68,005 lbs. tensile / A311 Grade 1035 steel - 85,550 lbs. tensile. Standards for steel vary country to country and choosing the wrong one for a lifting application is risky. Are these other manufacturers simply copying lifts and choosing available "steel" that best suits their supply needs or choosing the correct steel for the load path application?



### Statement from their website and other Marketing Materials

"Don't gamble with your investment. Trust the company that has been manufacturing the highest quality automotive lifts for home use and is the largest manufacturer of four post lifts to provide you with a product that you will be proud to own and feel safe using."

### **BendPak.** Response

Reduce the "gamble" by purchasing a lift from BendPak - a manufacturer involved not only in the hobby and DIY markets, but professional auto care, OEM dealerships, specialty equipment and commercial parking industries for over 40-years.



### Statement from their website and other Marketing Materials

"Have a classic car, collector car or antique car that you are working on or would like to store? We have the perfect automotive lift for you. Classic car restoration is a popular use for our products. Feel free to view our side-by-side comparison info which measures the quality and performance of the Backyard Buddy automotive lift against the characteristics of the typical imported economy lift. You will see that for safety, performance, durability and overall value the only choice is Backyard Buddy."

### **BendPak.** Response

With respect to a side-by-side product comparison of BYB to BendPak, this is propaganda, unwarranted and meaningless. BendPak does not fit the bill of "the typical imported economy lift". BendPak urges you to look-compare-and-decide before making your purchasing decision and no matter what propaganda is thrown at you, think rationally, wise and with reason. Learn to separate fact from fiction. Above all – don't be suckered into thinking that just because it costs more, it must be better.



### Statement from their website and other Marketing Materials

Other lifts are made from lighter gauge metal with channels that are cold formed creates weak points at the bends."

### **BendPak.** Response

Again, more propaganda - cold-formed steel is widely used in buildings, automobiles, equipment, utility poles, storage racks, highway products, and bridges.

ADVANTAGES OF COLD-FORMED STEEL - Cold-formed steel products are shaped at ambient temperatures from steel sheet, plate or flat bars by roll-forming machines, or press brakes. They can be produced in large quantity and at high speed with consistent quality. In addition, cold-formed steel possesses many advantages over other construction materials: (1) Cold-formed steel components weigh approximately 35% less than other counterparts, but with equal or better strength characteristics. (2) As a result of the cold-forming process, cold-formed steel possesses one of the highest strength-to-weight ratios of any building material. This high strength and stiffness advantage means better design flexibility, wider spans and better material usage. (3) Cold-formed steel does not expand or contract with moisture content. In addition, it does not split or warp as time goes by.

## Formed Metal Building Construction

In pre-engineered metal buildings, entire building structures are made from steel products, and approximately 40-60% of the total steel used is cold-formed steel.

Curious question you should ask yourself – the cost of press brakes, bending brakes and roll-forming machines to accommodate material this size is very costly - is that the reason many smaller sized lift companies choose alternative methods of manufacturing?



### Statement from their website and other Marketing Materials / Leg Construction

"Other lift suppliers need stamped holes in foot to add stability to lift by anchoring it to the floor. Backyard Buddy requires no anchors".

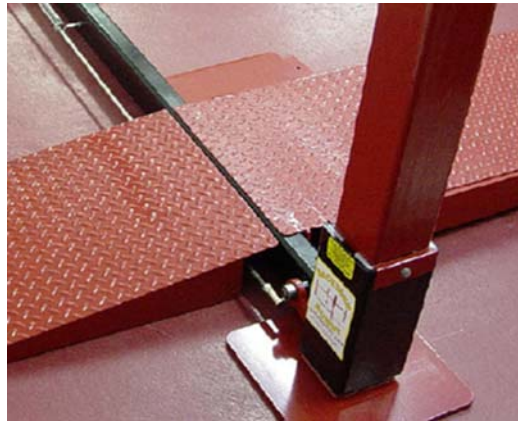

### **BendPak** Response

BendPak adds anchor holes to the lift base plates because many buyers choose to bolt their lifts to the floor and BendPak's certification was awarded WITHOUT BEING ANCHORED. BYB implies that bolting the columns to the floor offers no real stability benefit which is absurd. With BendPak four post lifts, you have a choice - secured or free-standing. During the entire first half of the hit show Monster Garage, at their original set location, with all the hammering and banging going on, their BendPak lift was never anchored to the floor. (The lift needed to be mobile because after the vehicles entered the work area, the film crew had to rotate the lift 90-degrees to accommodate the proper camera angle.)





Statement from their website and other Marketing Materials / Leg Construction

"Other lift suppliers use anti-spread bolts at top to keep legs from opening when weight is added to the lift."

**BendPak** Response

BendPak lifts do not incorporate an "anti-spread" bolt and are not prone to "opening" when loaded.



Statement from their website and other Marketing Materials / Leg Construction

"BYB columns are made from rugged, structural 4X4 steel tubing."

**BendPak** Response

BendPak urges you to talk to a qualified structural engineer and ask if the loads being placed on the columns would be significant at all to warrant excessive design(s). The columns on all BendPak four-post lifts were tested and certified at 27,000-pounds are designed with a safety-factor that far exceeds 300% of the rated load capacity required to meet ANSI/ALI ALCTV-2006.

1			
2	<b>BendPak HD-9 4-Post Lift 6.12 Inch Pulleys with 10 mm cable / ALI</b>		
3	Post	<b>H-464</b>	
4	bx (In) <sup>4</sup> =	7.65	
5	Area (Sq. In.) =	2.18	
6	Rxx =	1.87	
7	Length (Inches) =	99.87	
8	L/ Rxx Ratio =	53.31	
9	Compressive Load (Pounds) =	2,500	<b>Safety</b>
0	Compressive Stress (Psi) =	1,147	<b>Factor</b>
1	ALI Allowable Bending Stress (Psi) =	54,525	47.55
2			
3	Critical Buckling stress (Psi) =	25,177	10.07
4			
5	<b>Cable Connector Plate</b>	<b>H-415</b>	
6	800194 Contact Area (Sq. In.) =	1.58	
7	800194 Perimeter length ( In.) =	4.46	
8	H-415 Plate Thickness (In.) =	0.79	
9	Tensile Load (#) =	2,873	
0	Shear Area (Sq. In.) =	3.51	<b>Safety</b>
1	ALI Allowable Shear Stress (Psi) =	54,525	<b>Factor</b>
2	Shear Stress (Psi) =	818	66.67
3			
4	<b>Cable Connector Nut Strength</b>	<b>ASTM</b>	<b>P/N 800195</b>
5	Material	<b>A 108 CRS</b>	
6	Ultimate Strength (Psi) =	97,500	
7	Thread =	M18 x 2.5	<b>Safety</b>
8	Minimum Length of Nut (In.) =	0.94	<b>Factor</b>
9	Tensile Stress Area of Thread (Sq. In.) =	0.17	P1510 (2a) M Handbook
0	Load to Fail the Thread (#) =	16,564	6.63
1			
◀ ▶ Safety Cable Load Input Ramp Ganged Pulley & Pin Beams & Attachments Cor			



Statement from their website and other Marketing Materials / Leg Construction

"Other lift suppliers use plastic sliders on the inside of the legs that wear over time as they rub on metal increasing the possibility of failure."

**BendPak** Response

BYB uses "plastic" sliders on their cross tubes so why would they discredit their use? The below photo illustrates the BYB plastic sliders which are external rather than internal. Curious question – would you be encouraged to grease the BYB columns to keep the sliders free - and if so, does that not make a mess on the outside of the columns? Another question - will the nice paint finish on the BYB columns become dull with abrasion marks after use?

## BYB NYLON SLIDE BLOCKS



BendPak also uses UHMW slide blocks placed internally as opposed to externally.

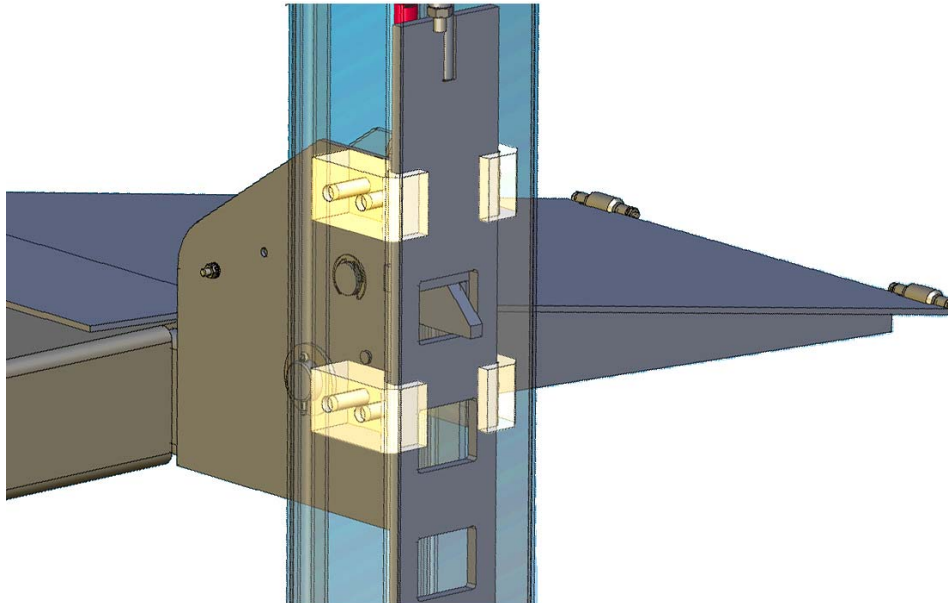

The "plastic" for BendPak sliders is not "plastic" but rather UHMW (Ultra-High Molecular weight) Polyethylene. There is little if any load on the slide blocks so they will not "wear over time" like BYB suggests. UHMW is often referred to as the world's toughest polymer. UHMW is a linear high density polyethylene which has high abrasion resistance as well as high impact strength. UHMW is also chemical resistant and has a low-coefficient-of-friction which makes it highly effective in a variety of applications. BendPak slide blocks are simply guides that keep the cross tubes and safety ladder centered within the column and minimize sway.

BendPak lifts feature cable sheaves that are precisely centered within the cross tube meaning the cross tube tends to stay level during the entire lifting motion thereby eliminating side loads of any kind. BYB lifts employ cross tube sheaves and axles that are located outside the cross tube body forcing the cross tubes to twist or rotate away from the sheave as the lift raises. This twisting occurrence tends to develop side-loading on their cross tube components and plastic sliders.



## Statement from their website and other Marketing Materials / Leg Construction

"BYB uses a closed steel leg surrounded by an exterior steel support jacket that ensures positive contact and does not create an opportunity for legs to fail under the weight of your vehicle."

## BendPak Response

There is a reason that BYB is probably the ONLY lift company in the world (out of approximately 200 globally) to use this design. That's because it makes a better brake than a lift component. Think of an adjustable welding clamp or other slide-lock type device - they employ similar design features. Columns that use this design feature are more apt to seize should an unlevel situation occur.

Below is an actual forum posting on [www.corvetteforum.com](http://www.corvetteforum.com)

Here are a few threads I posted on my Bend Pak HD-9 installation.

<http://forums.corvetteforum.com/show....php?t=1468748>

<http://forums.corvetteforum.com/show....php?t=1470876>

<http://forums.corvetteforum.com/show....php?t=1658540>

I will only speak to the two types / brands of 4-post lift I am most familiar with - the AutoLifters which a friend of mine owned (AL now out of business but being produced by former AL employees - same design as the BYB) and the Bend Pak HD-9 I currently own. I spent many a weekend under the AutoLifters (7K lb. cap.) over a few years and have owned my HD-9 (9K lb. cap.) for a year now.

The AL uses the fully boxed post section with collar-style crossbeam ends while the BP has a C-channel post design with internal runners that slide on ladder locks suspended from the top caps.

There seems to be a perception that the C-channels can spread under load, but that's not how these lifts work. There is virtually no side load on the posts and certainly nothing to splay the channels apart during raising or lowering. Basically, they are cable and pulley systems with crossbeam and column supports to manage the transmitted loads.

What's important is that the members remain stationary (rigid) and no one corner binds - or lets loose - during the lifting or lowering process, destabilizing the equilibrium enough to allow one of the posts to tip too far.

The posts can actually tilt in/out a certain amount without destabilizing the lift and toppling it. I've seen this happen twice in person - once on the AL lift when one of the manual lever-actuated locks didn't engage while lowering and the other the first time I actuated my BP and one of the cables was still too loose. Both times, the tilt in the post was completely recoverable because the lift was not allowed to travel beyond one lock level. Remember that the entire mechanism is tied together with a tensioned cable system and tends to want to stay tied together rather than spread out.

I have noticed that neither design has more tendency for the corner attachments to decouple from the post or allow post tilt. Both designs are quite secure. What I have noted are the differences in lock designs which is the reason I went with my BP. The BP has a double lock system - the first is a pneumatically-actuated, "normally-closed" set of ladder locks. These are the primaries and the only way for these to allow the lift to lower is to keep one's hand on the release button and hydraulic release continuously and simultaneously until the lost lock is passed. The secondary, "slack-cable" set of locks are purely for safety. Should a cable break or go slack for any reason, that corner lock will release and automatically lock into the next detent, not allowing that corner to drop uncontrolled. This was the failure suffered recently by an AL lift with pictures posted here.

<http://forums.corvetteforum.com/showthread.php?t=1419373&highlight=autolifters>

I'll qualify that link by saying that could have been prevented with proper maintenance and replacement of a faulty pulley setup that the manufacturer warned of. But it does illustrate that, ultimately, it's up to the owner/operator to safely install, maintain and operate his lift. Also, high quality components and construction are vital when weighing the issues of cost and safety. My Bend Pak is made in America with solid engineering backed by decades of commercial lift design and construction, high-strength, high-quality components and great workmanship, including beautiful welds. The cost was comparable to the competitors too.

I spent a lot of time researching lifts before ordering mine and I still believe I'd make the same choice today that I did when I chose the BP. Others have their own thoughts and opinions - and requirements. My decision was between the All American, the Revolution (Rotary), the Backyard Buddy and Bend Pak. Cost was not the primary factor, safety was. Check all the certification and testing that a manufacturer does on its lifts - that alone is a very educational process. Whatever your choice is, have a healthy respect for the potentially dangerous piece of heavy equipment that a lift is. Safety should be foremost on your mind always when working around a lift. That behavior alone should keep it a safe and fun piece of equipment to own.



**Statement from their website and other Marketing Materials / Leg Construction**

“BYB uses a closed steel leg surrounded by an exterior steel support jacket that has no chance for leg to spread open.”

**BendPak** Response

Loads are insufficient enough to cause any spreading so continuing to highlight this feature is solely propaganda. However, because of their external tube sliders, BYB can't mount their 95-pound power unit securely to a column - instead it is mounted on a wobbly motor stand that is positioned uncomfortably low (they make the pole stand short to minimize flex) causing operators to slouch when reaching for the controls.

BYB POR UNIT MOUNTED ON STAND

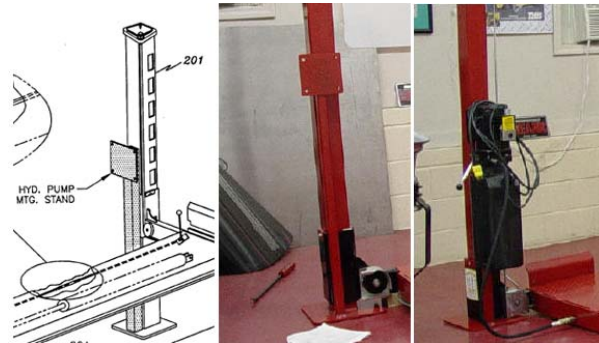

BENDPAK UNIT ATTACHED FIRMLY TO COLUMN



**Statement from their website and other Marketing Materials / Leg Construction**

“BYB features all steel construction, no plastic components provide a more durable performance and a stronger lift solution.”

**BendPak** Response

BendPak has never, or ever intends to use plastic components for any suspension specific part. In regards to “more durable performance” the BYB sheave design does not compare to BendPak. The axles on BYB cross tubes are supported only at one end which means the loaded cable sheaves are constantly trying to bend the axle rod when loaded. If the axle yields under load, even if slightly, the axle will not remain perpendicular with the load path. This will cause non-concentric movement of the sheave causing premature wear of parts and cables. BendPak sheave axles are supported at both ends so the axles and sheaves remain exactly perpendicular to the load path at all times.



### Statement from their website and other Marketing Materials / Runway Construction

"Other lift suppliers make their runways from soft tread plate which is bent to form the runway creating weak points at the bends and no under runway reinforcement means more flexing of runway surface. BYB runways are made from a superstructure of angle iron topped with tread plate. Welded flat stock ties sides together under the runway surface adding an additional level of support and integrity to the lift."

### **BendPak** Response

There is no such thing as "soft tread plate" so this is purely propaganda. The steel used on BendPak runways far exceeds 58,000-lb. yield which is equal to or better than standard "pig iron" diamond plate whose purpose is primarily for traction rather than strength. BendPak runways were tested and certified at 27,000-pounds and are cold-formed steel. They also feature under runway reinforcements that create a box shape for increased strength and stiffness. Cold-formed steel possesses one of the highest strength-to-weight ratios of any building material. BendPak lifts are designed and tested to meet the only REAL lift certification standard, ANSI/ALI ALCTV-2006, with a safety factor that exceeds 300% rated load capacity - enough said.



### Statement from their website and other Marketing Materials / Hydraulic Connections

"Other lift suppliers provide no quick disconnect. L shaped coupler with Teflon tape means that hose can kink and cause a blow-out. No flow restrictor means that the lift will instantly slam to the ground in the event of a blow-out. Quick connect means that hose will not kink and can swivel. Installed flow restrictor means that the lift will maintain position even in the event of a problem with the hose. don't cut corners when it comes to your safety and the protection of you vehicle and property."

### **BendPak** Response

All of BendPak lift cylinders use internal flow-restrictors to prevent rapid fall in case of a hose or fitting failure. This is a worldwide safety standard that is required for all commercial lift manufacturers. International lift standards prohibit the use of quick-disconnect fittings on vehicle or personnel lift applications. Quick disconnect fittings have spring loaded ball-in-seat components. If the ball does not "seat" like you expect it due to contamination or faulty ball-seat, there is nothing to shut off the flow of oil and the uncontrolled descent of your lift. Hose "blow-outs" simply do not occur under normal use. As part of the ANSI/ALI ALCTV-2006 standard all BendPak hoses have a 400% safety factor based on the pressure required to operate the lift at its rated load capacity.



### Statement from their website and other Marketing Materials / Locking System

"Other lift suppliers use only a 3/4 inch contact surface for locking mechanism. Very unstable when you combine this with the loose construction which causes the lift to sway."

### **BendPak** Response

This does not apply to BendPak lifts as their design is not at like BYB describes. All BendPak four-post lifts do employ eight independent safety lock devices, four primary and four back-ups.

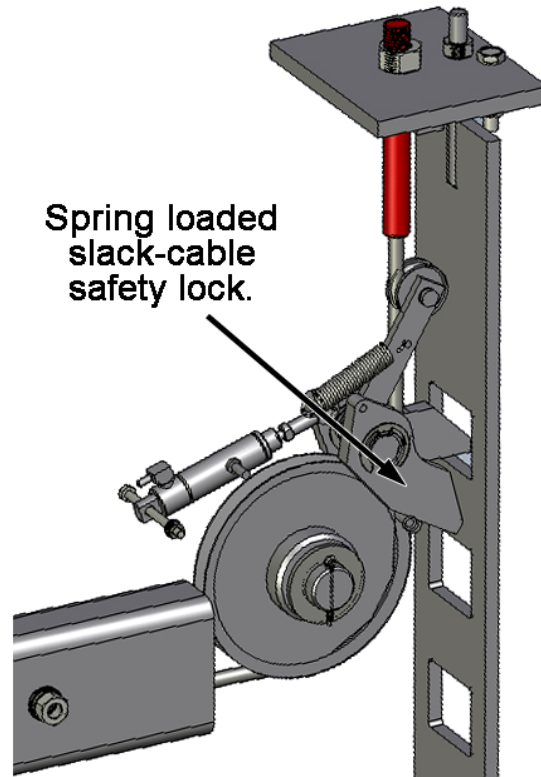

Statement from their website and other Marketing Materials / Locking System

"Other lift suppliers use a formed channel leg design that creates pivot point on the legs for the lift platform to sway on. Try pushing their lift and you will see how much it moves."

**BendPak.** Response

BendPak lifts are just as solid as BYB and experience virtually no sway. Through numerous inquiries and research and countless on-site testing of lifts in use, BendPak lifts experience less sway than BYB, Auto-Lifters or other external tube designs.



Statement from their website and other Marketing Materials / Locking System

"Other lift suppliers use stop points that are made from welded tabs on the legs."

**BendPak.** Response

BendPak's adjustable ladder provides adjustment for unlevel floors enabling your vehicle to sit safely in a level position even if your floor is unlevel - an important feature that BYB lacks. BendPak features additional lock positions providing greater versatility.

BENDPAK SAFETY LOCK SYSTEM  
FEATURES SLACK-CABLE BACKUP

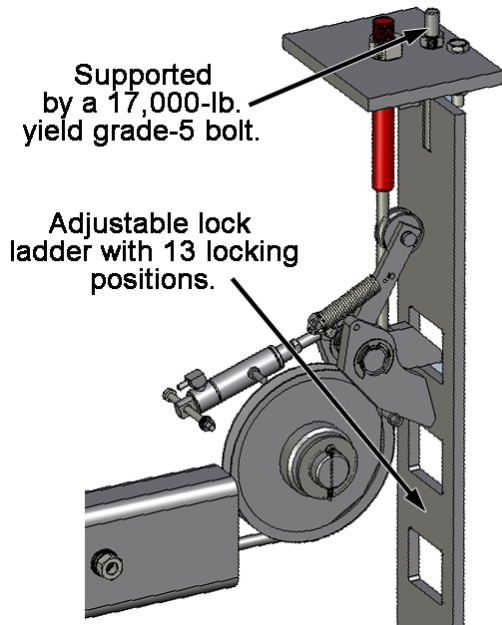

BYB FIXED COLUMN LOCKS

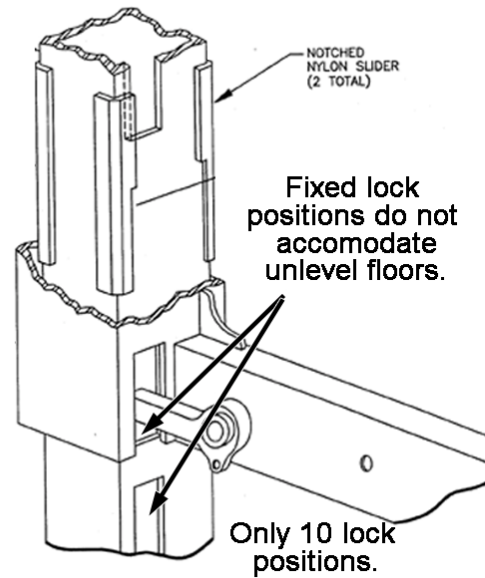

Statement from their website and other Marketing Materials / Locking System

"Other lift suppliers use 1/4" billet rod for their locking systems that allow for bowing and more problems for you. BYB uses 3/8" rod that ensures positive locking and no bowing."

**BendPak** Response

BendPak commercial-grade pneumatic safety lock system ensures that your locks release simultaneously every time. BYB lifts use linkage rods to release the four spring loaded locks – that means a lot of resistance to overcome. That combined with the accumulation of slop for all of the linkage points means that the safety lock furthest from the operator has a good chance of not being "pulled back" far enough. Think about what would happen if three corners descended and one stuck. The worst cause of lift failures or vehicle "drops" are caused by the runways becoming unlevel due to seized column or stuck lock. Mechanical linkage systems are more prone to seizure and failure. Can you really see the far corner with a vehicle in the way?



Statement from their website and other Marketing Materials / Locking System

"BYB features 10 positive locking positions cut into the 4X4 structural steel tube legs, not welded on."

**BendPak** Response

BendPak features 13 adjustable lock positions providing greater versatility and storage height coverage. BendPak does not incorporate welded-on blocks as a stop device.



### Statement from their website and other Marketing Materials / Locking System

No lateral movements (sway) with virtually no chance of falling.

### **BendPak.** Response

BYB uses “plastic” sliders in the columns just as BendPak does. BendPak fits all cross tube lifting components precisely to minimize “sway” just as BYB does. Through numerous inquiries and research and countless on-site testing of lifts in use, BendPak lifts prove to experience less sway than BYB, Auto-Lifters or other external tube designs.



### Statement from their website and other Marketing Materials / Locking System

Steel locking insert goes into the leg cut out and the steel slider jacket rests on this to create a "fused" system for holding your lift in the exact position you intended.

### **BendPak.** Response

Huh – “fused” system?

### Final thoughts:

BYB is a qualified and respected supplier of lifts, but from a design standpoint, their lift doesn't even come close to a BendPak. Not one component on their lift exceeds the quality of a BendPak. If you review all of the BYB propaganda you will notice their entire sales pitch circulates around their column design. They purposely make it that way so that they have something “unique” to offer, that's it. It is only unique - it is not safer, better, stronger, or more stable.

There's a reason they spend 100% of their time boasting about their unique column design - because they don't want you to ask about ...

- Their much smaller sheave roller axles - BendPak uses 1-1/4" sheave axles. Not only for increased strength, but to add more surface area on the bearings to minimize friction wear.
- Their lack of cable-break safety device - BendPak four post lifts employ 8 independent safety locks - have back-ups for back-ups.
- Their lack of rugged enough cable-guides to make sure the cross tube cables stay put on their respective sheaves – BendPak cross tube cables are all routed internally through the structures and around internally mounted sheaves wedged between solid steel plates. It is IMPOSSIBLE for the cables to jump off. BYB has externally mounted cross tube sheaves that incorporate a sheet metal cover held on by a set screw lock ring. Not only does the set-screw lock ring hold on the cover, but it also keeps the sheave roller in place.
- Their lack of adjustment for accommodating unlevel floors. BendPak's adjustable ladder design provides adjustment for unlevel floors that enables your vehicles to sit safely in a level position even if your floor is unlevel.

Other BendPak design features;

- BendPak's cable block attached to the chrome rod features "outrigger" sleds that ride on the inside rails of the runways to ensure the cable block remains square at all times. Lifts that do not incorporate this device can experience cable block misalignment (the cylinder rod tends to rotate as the cylinder moves due to the inherent nature of the cables trying to "unwind" and/or the rifling surface inside the cylinder bore) which ultimately causes premature wear of cables and/or sheaves.



- BendPak's dual-hub sheaves feature 1-1/4" Oilite® oil-impregnated bronze bushings and have almost 400% more bearing surface area for increased life and durability.



*Bottom Line:*

BendPak lifts are actually sold for slightly less (in most cases) than BYB because BYB sells less volume than BendPak which forces BYB to charge more.